

# Skytile® Base Range

Installation instructions for Skytile® Base recessed LED panels



## Warnings and cautions

- To avoid electric shock, serious injury or property damage, isolate power before installing, removing or servicing the product
- It is recommended that luminaires are installed by a qualified electrician and the installation complies with the local current wiring regulations
- Any broken or damaged parts should be replaced as soon as possible. JCC will not accept responsibility for claims arising from any sub-standard installations
- It is recommended that the ambient room temperature should not exceed 25°C
- These products are designed for connection to a mains supply of 220-240V~ 50/60Hz
- This luminaire is suitable for indoor use only
- It may be necessary to upgrade your MCBs to allow for increased inrush current
- Do not cover with insulation
- Do not carry out insulation tests with the product connected to the circuit

## INSTALLATION

ENGLISH

- Read instructions and check that you have all of the tools and accessories required to complete the installation correctly. Isolate power supply before starting the installation.

Type	Wattage	Colour Temp	Lumens	LpcW
600 x 600				
TP(a)	30W	4000K	3000	100
TP(b)	30W	4000K/5000K	3150	105

Specifications Ra: 83

### Standard non-dimmable/dimmable luminaire installation

- Remove the ceiling tile or tiles from the location where you wish to install the LED panel.
- Wire the LED driver to the mains supply as indicated in figure 1. If a dimmable variant, connect the dimming control wires (DALI/1-10V) as shown in figure 2.
- Move LED panel into the ceiling aperture and when positioned halfway connect the driver low voltage output to the LED panel (luminaire) as shown in figure 1.a.
- Position the LED panel into place in the grid ceiling.
- Reconnect mains power supply and test for operation.

### Wiring connection

220-240V 50/60Hz / Class II

Fig. 1. Mains Input Cable

Fig.1.a. Luminaire connection

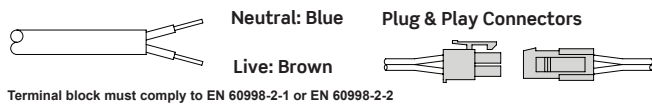

700mA/27-42V DC / Class III Non-dimmable

700mA/6-43V DC / Class III DALI/1-10V dimmable

### Dimming control input

Figure 2.

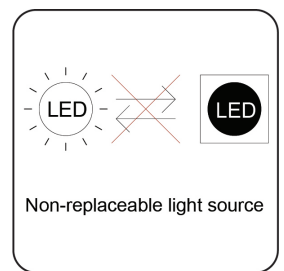
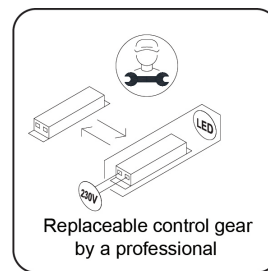
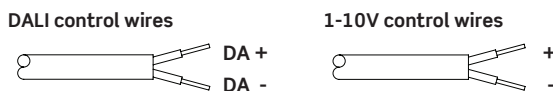

## Profile & Dimensions

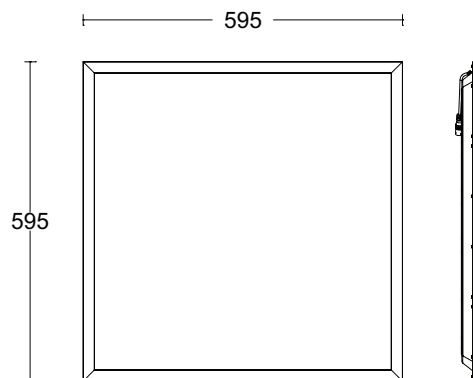

All dimensions in millimetres

# Mounting options

## Grid ceiling

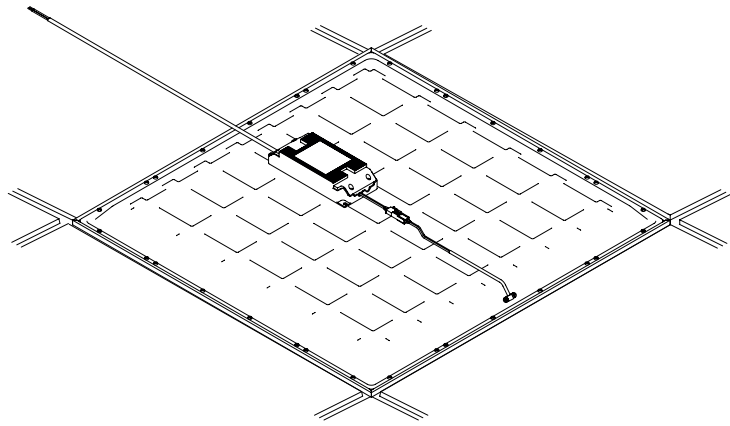

## Surface mounting box

Surface Mounting  
JCC can also supply a  
Surface Mounting Tray.

Please ensure there  
is adequate clearance  
around the fitting to  
allow access  
to the panel.

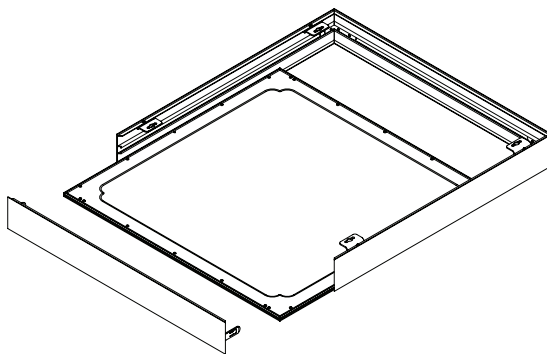

JC71262- 600 x 600mm  
JC71295- 1200 x 600mm  
JC71299- 1200 x 300mm

## Wire suspension

Suspension Mounting

JCC can also supply a Wire Suspension Kit for  
applications where a ceiling grid is not available

JC080050 - 4 wire 1.5m Suspension Kit for use  
with Skytile Base (JC080046-49 & JC080051-52)

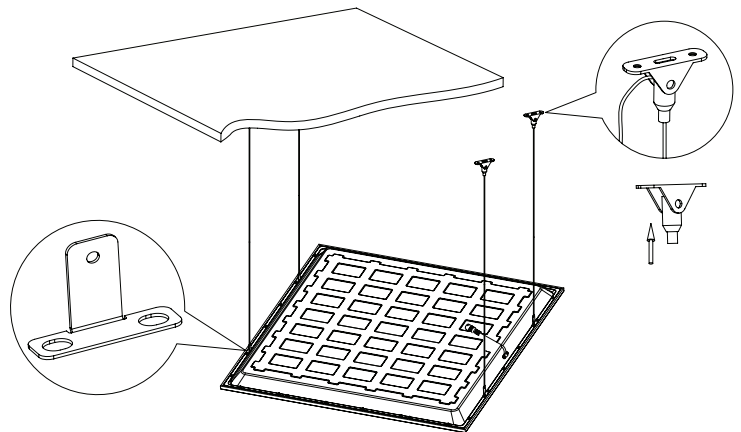

You can help protect the environment. Please remember to respect the local regulations: hand in the non-working electrical equipment to an appropriate waste disposal centre.  
The packaging material is recyclable. Dispose of the packaging in an environmentally friendly manner and make it available for the recyclable material collection service.

## Important warranty information

This product is supported by a 2-year standard warranty which will extend to 5-years if registered within the first year of purchase.  
Please register at [jcc.co.uk/warranty](http://jcc.co.uk/warranty) (Terms and conditions apply).

The installer will be asked to provide the following information, which is detailed on a label attached to the luminaire's chassis:  
Product Code/Date Code.

Recommended remote emergency packs:



JCEM002- JCC Emergency Remote Pack  
JCEM002ST -JCC Emergency remote pack self-test

**jcc.co.uk**

BS EN ISO9001 - 2015 - Registered Firm Certificate No. GB 1552  
JCC Lighting Products Ltd. Lux Park, Chichester Business Park, City Fields Way, Tangmere, Chichester, West Sussex, PO20 2FT  
**Technical Support: +44(0)1243 838986 Customer Services: +44(0)1243 838999**