

READ THESE INSTRUCTIONS THOROUGHLY BEFORE INSTALLATION KEEP THESE INSTRUCTIONS FOR FUTURE REFERENCE.

IMPORTANT:

This product must be installed by a qualified electrician or competent person, and in accordance with current building and IET wiring regulations.

BOX CONTENTS

This lighting fixture has been properly packed to avoid damage during transit. Before commencing with the installation carefully inspect the luminaire to confirm there is no damage. DO NOT INSTALL if any damage has occurred to the fixture or any of its components:

- Light Fitting
- Instruction Manual
- Fixings

INSTALLATION INSTRUCTIONS

1

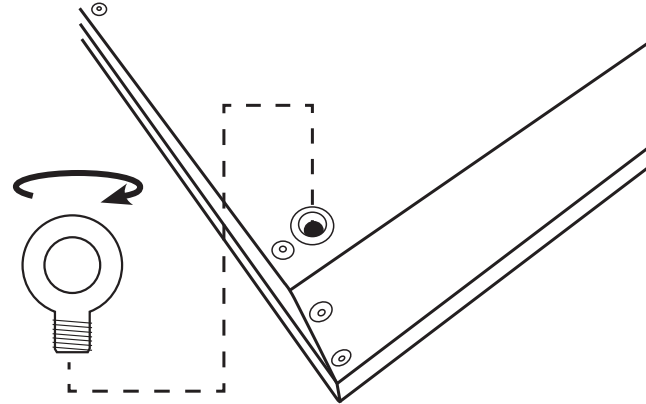

2

Electrical connection wiring

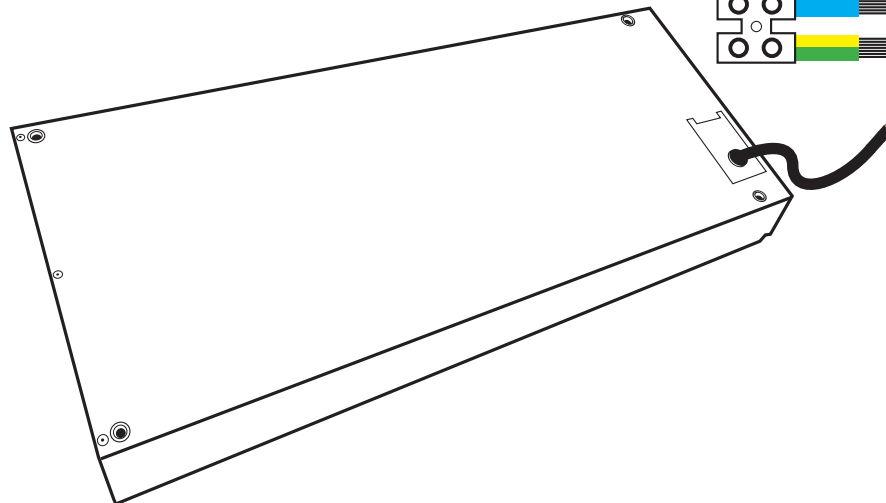

PLEASE READ THESE INSTRUCTIONS BEFORE INSTALLATION.



WARNING: Risk of electric shock! Isolate the mains power before proceeding.

- Turn off the mains power before performing inspections, installation, or removal
- Verify that the supply voltage is correct by comparing it with the luminaire label information
- It is the installers responsibility to ensure installation is suitable for the total load of the luminaire(s). The supply cable, fuses/circuit breakers must be correctly rated for the electrical load and considering for any transient inrush currents that may occur
- Do not perform insulation strength or resistance tests on installed luminaire(s) connected

1. Turn mains supply off, hand screw 4 x eye bolts (supplied), one for each corner. Hang light fitting using adequate chain or suspension wire. (See weights of fittings overleaf)
2. Wire as per diagram, ensuring a suitable connection method and/or junction box is used. Turn mains supply on when deemed safe.

For emergency information, see overleaf.

DISPOSAL

The light source of this unit is not replaceable; when the light source reaches its end of life the whole luminaire shall be replaced.

Disposal of Electronic Equipment WEEE Directive 2002/96/EC This product falls within the scope of the Waste Electrical & Electronic Equipment Directive (WEEE), which means the product should not be disposed of as normal household waste. Please recycle where facilities exist or check with your Local Authority.

RoHS - All components and materials used in this product are RoHS 2002/95/EC compliant.

Specifications may change from time to time. The information contained in this leaflet is for guidance only and should not be considered as always accurate and should be treated as not representative.

WARRANTY

This luminaire is warranted for a period of 5 years from the date of purchase**. The backup battery pack in the emergency version is warranted for a period of 24 months. The warranty could be invalidated should the light fitting not be installed according to these instructions, outside the scope of the specification or the product has been altered or tampered with in any way. Please see website for terms and conditions.

PRODUCT TEMP SPECIFICATION

Standard -20 to +40°C

Emergency 0 to +40°C

Revision 2.0 - November 2022

DERWENT DIMENSIONS

Part No.	Description	Watts	L (mm)	W (mm)	H (mm)	Weight
430120	Derwent Low Bay	100W	712	352	83	5.0kg
430121	Derwent Low Bay	150W	712	352	83	5.1kg
430122	Derwent Low Bay	200W	802	352	83	5.8kg

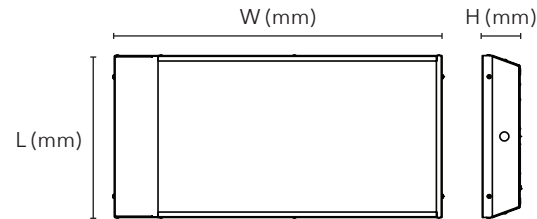

Installation Engineers Contact Details:		Luminaire Reference / Location
Name:	Tel:	

Luminaire Details:	Full Recharge Duration 24 Hours	Emergency Duration 3 Hours	Lamp Type LED

ROUTINE TEST RECORD

Type Test	Year 1		Year 2		Year 3		Year 4		Year 5	
	Signed	Date	Signed	Date	Signed	Date	Signed	Date	Signed	Date
Functional 1										
Functional 2										
Functional 3										
Functional 4										
Functional 5										
Functional 6										
Functional 7										
Functional 8										
Functional 9										
Functional 10										
Functional 11										
3hr Duration 12										

Wiring instructions for units equipped an with EMERGENCY function

Emergency lighting luminaires must be installed and maintained in accordance with the emergency lighting standard BS 5266-1

- The installation of an emergency fitting MUST BE CONNECTED AS SHOWN in diagram below, with SWITCHED live connected to the SL terminal and PERMANENT live connected to the PL Terminal
- For the emergency unit to operate correctly the permanent live feed must not be interrupted. Note: Ensure no lighting controls are on the permanent Live feed, such as PIR's or SWITCHES, failing to observe this will reduce the batteries lifetime of the emergency pack considerably
- After switching on an emergency equipped unit, the LED indicator should illuminate (visible through diffuser) this is to indicate battery is charging
- Should power to an emergency equipped unit be disrupted or isolated, the indicating LED will switch off, triggering the emergency function and illuminating the LED's
- The backup battery must be charged for 24 hours before a full duration test

EMERGENCY FITTINGS ONLY. EARTH CONNECTION REQUIRED.

- PERMANENT LIVE = Black
- SWITCHED LIVE = Brown
- NEUTRAL = Blue
- EARTH = Green/Yellow

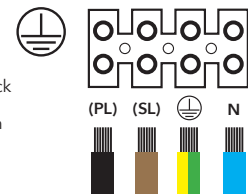

This product contains a light source of energy efficiency Class E.

Technical Helpline: +44 (0)1507 328031

** Please see our website for more detailed information on warranty.